



Meets OSHA Requirements
1926.502(b)(3) and (b)(4), 1910.29(b)(3) and (b)(4)
for Permanent Fall Protection

SAFETYGard™ RAILING SYSTEMS

The **Elite SAFETYGard Railing Systems** deliver the perfect combination of security and strength. The **Elite SAFETYGard Railings** are part of the **Elite COREGard Architectural Products** a brand of **Elite Fence Products**. Crafted from high-quality aluminum and powder-coated to the highest AAMA 2604 standards, it provides long-lasting durability with virtually no upkeep. It will not rust, warp, crack, or require painting, and it stands up beautifully to the elements year after year. Its clean, modern design complements any property, while easy installation makes it a smart choice.

Every railing system is engineered and fully tested to meet local building codes. Third party testing and evaluation reports are available. Elite's SAFETYGard Railing Systems are backed by a limited lifetime warranty.

- Tested to Meet or Exceed OSHA & ANSI Standards
- Engineered & Tested for Performance
- 3-Part Submittals Available
- Heavy-Duty Aluminum Railing with Stanchion Post Mounts
- Commercial and Industrial Applications



Buy American, Be American™ 

1.800.783.1331

www.EliteFence.com



SAFETYGard™ RAILING SYSTEMS

SAFETYGard Specs*:

Heights:	3' and 3 1/2'
Min. Strength:	35,000 psi
Alum. Alloy:	6005-T5 Alloy (Rails & Posts)
Posts:	3" x 3" x .125 Wall 4" x 4" x .125/.250 Wall
Hor. Rails:	1-5/8" x 1-5/8" with a 1" x 1" Internal Picket
Pickets:	3/4" x 3/4" x .050 Wall

*Custom designs may vary.

SAFETYGard Profiles:

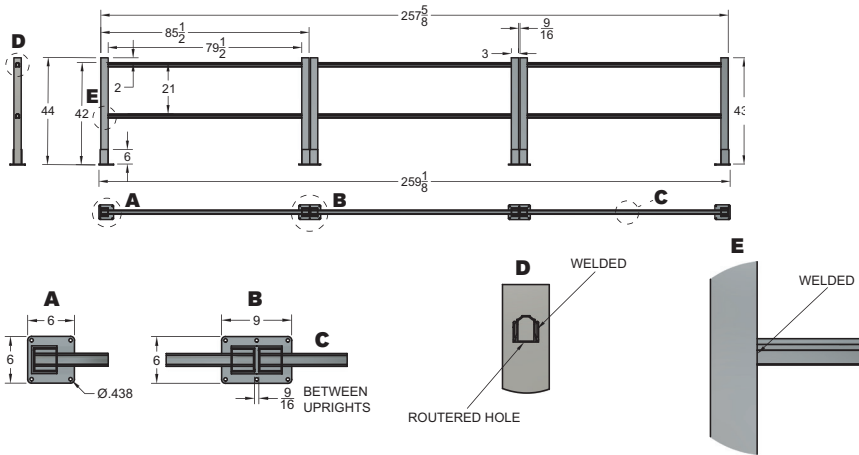
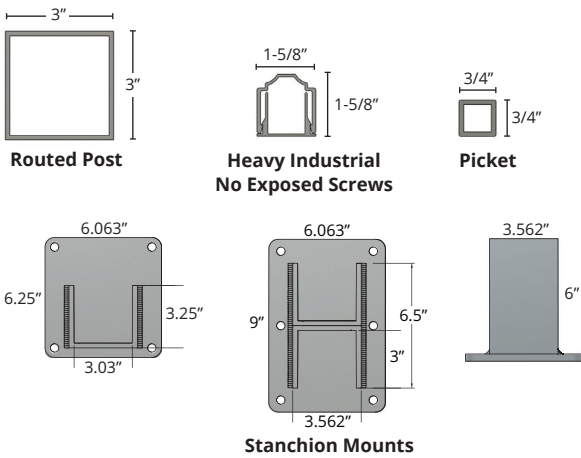

SAFETYGard Colors:

Textured (Matte) Black	Black	Beige
Textured (Matte) White	White	Hartford Green
Textured (Matte) Quaker Bronze	Quaker Bronze	Walnut Brown
Textured (Matte) Sandstone	Sandstone	

Colors shown are simulated and may vary.

SAFETYGard Resources:

Specifications, Drawings, Testing/Engineering, Brochure and Warranty

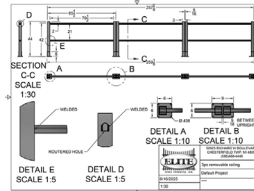

SAFETYGard Components:

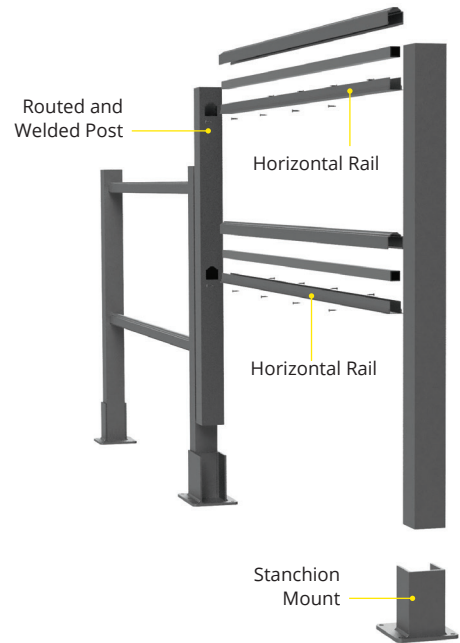

ECO-FRIENDLY



WIND/WEATHER RESISTANT



POWDER COATED
AAMA 2604-05



LOW MAINTENANCE



LIMITED LIFETIME WARRANTY



BUY AMERICAN
BE AMERICAN



50925 Richard W. Blvd. | Chesterfield Twp., MI 48051

Phone (586) 468-4448 | Fax (586) 468-4884

1.800.783.1331 | www.EliteFence.com